

XP600/1100 INSTALLATION AND OPERATION MANUAL



EXELTECH

7317 Jack Newell Blvd North
Fort Worth, Texas 76118-7100
817.595.4969 voice, 817.595.1290 fax
800.886.4683 toll free
e-mail address info@exeltech.com
e-mail address sales@exeltech.com
website www.exeltech.com

XP600/1100 INSTALLATION AND OPERATION MANUAL

Copyright © 2001 Exeltech Inc. All rights reserved. This Document may not be copied, photocopied, reproduced, translated or converted to any electronic or machine-readable form in whole or in part without prior written approval of Exeltech Inc.

Part Number: 931-X61M*-*0A

Acknowledgments

Project Management: Ben Baker and John Goetz

Writing: Gary Chemelewski

Copy Editing: Ben Baker

Art, Photography and Layout: John Goetz

July 2002

Exeltech
7317 Jack Newell Blvd North
Fort Worth, Texas 76118-7100

Table of Contents

| | |
|------------------------------|-----------------------|
| Introduction 1.0 | <i>page 3</i> |
| Standard Features 2.0 | <i>page 5</i> |
| Installation 3.0 | <i>page 8</i> |
| Operation 4.0 | <i>page 11</i> |
| Appendix A | <i>page 12</i> |
| Appendix B | <i>page 14</i> |



Introduction

1.0

Thank you for purchasing the finest sine-wave inverter in the power conversion industry. Exeltech's journey to excellence includes the first affordable sine wave inverter, first modular inverter system, first N+1 redundant inverter system, and the cleanest sine wave output in the industry. Exeltech strives to manufacture products of the highest possible quality, and is dedicated to 100% customer satisfaction. Proudly built in the USA with American parts, Exeltech is committed to TL 9000 standards and beyond, adding people and procedures continually to further improve quality and customer service. We welcome you as a customer to the Exeltech family. Congratulations!

XP series inverters provide the cleanest, best regulated sine wave output over the widest DC input of any inverter on the market today. They are extremely low in Total Distortion; specified to 2%, and typically better than 1.5%. Total Harmonic Distortion is typically 0.8 to 0.9%. Remaining distortion is a result of residual switching noise, which amounts to a very clean 25 KHZ sine wave superimposed on the fundamental output. No significant harmonics of 25 KHZ exist. This spectral purity will exist over the inverter's entire operating envelope, including non-linear and reactive loads. As long as peak output current remains less than 300% of rated current, total harmonic distortion will remain within the 2% spec. Peak current capability of the inverter is key to understanding it's operational envelope. As long as the inverter is supplying less than this amount, it will function properly and operate virtually any load.

Many inverters are rated in Volt-Amps (VA), as opposed to Watts. This is in an attempt to make an inverter or UPS (Uninterruptible Power Supply) appear larger than it really is. The only fair way to

specify these products is in Watts (W), which is power the inverter can actually deliver. If Exeltech inverters were specified in VA, Our 1100 Watt inverter could be rated at 1375 VA at .8 power factor, 1570 VA @ .7 pf, or an incredible 2200 VA @ .5 pf. It is confusing to specify a product in VA, because the power factor must also be specified. Exeltech's XP-Series inverters can output their full rated power continuously at 30° C (86° F).

The inverter can maintain a spectrally pure output with any load, due to a specially designed non-linear control loop in the primary DC to DC converter. This circuitry is one of three circuits which protect the inverter from any overload condition.

XP-600 and XP-1100

These inverters can supply twice their rated output power for 3 seconds, in order to start motors or supply in-rush currents to electronic loads. If output power is exceeded for greater than 3 seconds, output voltage is reduced to a level which will provide the inverter's rated power to the load by clipping tops of the waveform. The inverter can operate safely in this mode indefinitely. Should the overload condition clear, the inverter will again provide the cleanest Sine Wave in the industry. This over-current circuitry insures maximum peak current does not exceed 300% of rated RMS current. Should this number be exceeded, it will again reduce output voltage as required to maintain that limit. Again, the inverter can operate in this mode indefinitely, so that when the overload clears, output voltage is automatically restored. The third protection mechanism is short circuit. If the inverter exceeds it's peak current (Ip) capacity for a prolonged period, it will shut off automatically. The period of time required to shut off changes with the degree of overload. A high overload shuts off in one second. A slight overload may require several seconds. This typically requires a .5 ohm load per 1000 Watts, for several seconds. This guarantees the inverter is disabled, in the event that the user attempts to clear the short without first shutting off the inverter. The inverter in fact, acts as an extremely high performance circuit breaker. The short circuit and overload circuitry responds much faster than any normal fuse or breaker, so no external current limiting devices are necessary. Exeltech's XP-Series inverters can output their full rated power continuously at 30o C (86o F). The inverter is derated 20% of its

full power for every 10 degrees C over 30 degrees C. IE; 80% of normal capacity at 40 degrees C, 60% at 50 degrees C . . . etc.



Standard Features 2.0

DC INPUTS: Positive (+) and Negative (-) input terminals are 5/16" studs with brass hardware. They are accessed under the Rear Cover. Use Appendix "A" to choose the appropriate gauge wire for your specific model.

REMOTE ON/OFF: provides the User with a remote method to turn the inverter on and off. "REMOTE" connection is on the barrier terminal strip located under the Rear Cover.

AC OUTPUTS: All models (*except 230 VAC output) have two, NEMA -15 outlets (standard wall receptacle), located on the Front Panel. Additionally; may be hard-wired to appliance / load using connections on the barrier terminal strip, located under Rear Cover.

* **XP-1100, XP-600 230 VAC**, inverters have an IEC-320 receptacle located on the Front Plate.

COOLING: is provided by a thermostatically controlled brushless fan located on the Front Panel.

DC POWER ON LED: located on the front panel, will be "ON" when inverter is powered up, and DC power is available.

LOW BATT / THERM BUZZER: produces an audible alarm if DC input voltage falls to a level within 2% to 4% of the low limit of inverter, or, if there is an over temperature condition.

ON/OFF SWITCH: located on front panel; turns the inverter on and off.

OVER VOLTAGE PROTECTION: If input voltage to the inverter exceeds set limits, the inverter will immediately and without warning shut off. When input voltage returns to normal range, the inverter will immediately restart. Since high over voltages tend to have very fast edges, the inverter must shut down quickly to protect itself. This kind of fault usually occurs if the battery is suddenly disconnected from the system and the battery charger continues to supply current.

UNDER VOLTAGE PROTECTION: When battery voltage falls to within 2% to 4% of low line voltage, the LOW BATT / THERM buzzer will sound. If the condition continues without reducing load to the inverter or adding charge to the battery, the inverter will shut off. When voltage rises to approximately 95% of nominal battery voltage, the inverter will turn back on and the alarm condition will clear. The inverter can be manually reset by cycling the on/off switch. This will reset the protection circuit and turn the inverter on at any voltage above minimum voltage.

OVER TEMPERATURE PROTECTION: The inverter is also protected against overheating. It will provide its full rated output up to the temperature listed in the specification sheet. If it is subjected to higher ambient temperatures or air circulation is blocked, the inverter may overheat. If the LOWBATT/ THERM buzzer sounds, immediate action is required or the inverter will shut down. Either reduce load, or provide more cooling in the immediate environment. If no action is taken, the inverter will likely shut down within 2 minutes. When the inverter shuts down, the alarm condition will persist and the cooling fan will continue to run. Since the inverter has eliminated its load, it will cool fairly quickly. It will automatically restart when it has cooled sufficiently, and the LOW BATT/THERM alarm will clear. "105 C internal temperature. Warning buzz 5 C before shut off".

OVERPOWER, SHORT CIRCUIT PROTECTION: The inverter has three levels of overpower protection. The first limits peak instantaneous current. The second system limits absolute power coming from the module. Both of these circuits act to reduce output

voltage as required, to limit current to a safe level. The overpower protection circuit will recover instantly when the overpower condition clears. The third, is short circuit protection. If the over current condition is so severe that it causes output voltage to collapse to 1 Vp for more than 1 second, the inverter will shut down and not automatically restart. This requires the user to clear the short circuit safely, and guarantee that hazardous voltage will not come back on line until desired. To reset the inverter from this condition, cycle power switch "OFF" then "ON" again.



Installation 3.0

CAUTION: It is essential to read and understand all Warnings, Cautions, and Notes before any connections are made to the Unit or System. If further assistance is needed call (817)595-4969 and ask for Customer Service.

WARNING: The inverter is designed to operate from a Battery. Performance cannot be guaranteed, and damage can result when a charger or power supply is used without a battery in the circuit.

WARNING: The AC neutral lead is internally bonded to chassis; chassis must be bonded to earth ground through the external ground connector that is located on the unit. The Negative or Positive terminal of the battery (DC Source) must be bonded to earth ground; it is recommended that it be to the same earth ground used for AC ground. Refer to the figure below for wiring illustration.

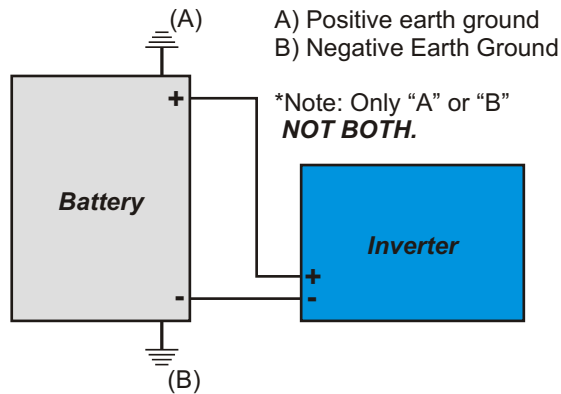

CAUTION: Before any connections are made to the Unit or System, be sure to disconnect the battery terminals. Always disconnect the grounded battery terminal first. When re-connecting, connect ungrounded terminal first, and grounded terminal last.

CAUTION: Polarity of leads is critical to avoid damage to the unit or system. Check batteries and battery cables for correct polarity and voltage.

CAUTION: Observe all National and Local Electric Codes when connecting AC Power Connections.

INSTALLATION (Location)

Mounting location is critical to performance and life span of the inverter. Heat and Moisture are the two worst enemies of any electronic device. Therefore, when choosing a mounting location, consider the following requirements listed in order of importance:

1. Inverter must be sheltered from the elements. Select a clean, dry location.
2. Inverter requires adequate ventilation for cooling. With proper cooling, the inverter will operate efficiently and meet its published ratings. All models can be mounted in several positions. Best position, with fan down. Second best, horizontal. Third, vertical with fan up. Least preferred, upside down.
3. Inverter should be mounted as close to the battery as possible. Shorter wire has less resistance, which translates to increased efficiencies.

INSTALLATION (Wiring)

An in line fuse is recommended, to protect the battery and wiring to the inverter. This fuse should be located very close to the battery positive (+) terminal. To select appropriate size fuse, consult the "Rated and Peak Current" table in appendix "B".

XP-600 and XP-1100: Positive (+) and Negative (-) input terminals are 5/16" studs with brass hardware. They are provided under the Rear Cover. Use Appendix "A" to choose the appropriate gauge wire for your specific model and distance from the battery.

1. Disconnect the **grounded (-)** terminal of battery and make sure the charger and inverter are off.

2. Make DC input connections to the inverter as illustrated in Appendix “C”.

3. (Optional) Using 12-18 AWG wire, make Remote On/Off connection from the Rear Panel terminal labeled “REMOTE” to one pole of a small toggle switch. Then from the other pole of toggle switch, make a connection to battery negative (-).

4. Make sure the toggle switch is off.

Note: in order for the Remote On/Off switch to operate inverter, On/Off switch on the Front Panel must be off.

5. If the Appliance / Load will be hard wired to the inverter instead of, or in addition to, using the outlets provided on the Front Panel, see Appendix “C”.



Operation 4.0

TURN ON INVERTER:

XP-600 and XP-1100: Turn inverter on using Toggle Switch on Front Panel, or the "REMOTE" switch if installed. LED next to the switch will illuminate, indicating the inverter is operational.

Note: If using "REMOTE" switch, the Front Panel Switch must be off. (If either switch is "on", the inverter will turn on. Both switches must be off for the inverter to turn off.)

TURN ON APPLIANCE/LOAD:

1. Check Input Power Requirements of the appliance. Make sure that it is less than Rated Output Power of the inverter. If more than one appliance will be run simultaneously, the sum of their Input Power Requirements must be less than Rated Output Power of the inverter.
2. If Appliance/Load has been hard wired to the barrier terminal strip as illustrated in Appendix "B", then turn appliance on. Otherwise;
3. Plug the appliance into the provided receptacle on Front Panel, then turn appliance on.

Note: It is recommend that the inverter be turned ON before the appliance/load.

APPENDIX A

Input Power Requirements:

| MODEL | NORMAL VDC | MINIMUM VDC CUT-OFF / ALARM | MAXIMUM VDC | RATED CURRENT | PEAK CURRENT |
|------------------|------------|-----------------------------|-------------|---------------|--------------|
| XP-600 / 12VDC | 13.8 VDC | 10.4 / 10.6 VDC | 16.5 VDC | 58.8 A | 66.6 A |
| XP-600 / 24VDC | 27.6 VDC | 19 / 21 VDC | 33 VDC | 29.4 A | 33.6 A |
| XP-600 / 48VDC | 55.2 VDC | 41.5 / 42.5 VDC | 62 VDC | 14.7 A | 16.6 A |
| XP-600 / 66VDC | 75.9 VDC | 57.5 / 58.5 VDC | 91 VDC | 10.7 A | 12.1 A |
| XP-600 / 108VDC | 124.0 VDC | 94 / 95 VDC | 149 VDC | 6.5 A | 7.4 A |
| XP-1100 / 12VDC | 13.8 VDC | 10.4 / 10.6 VDC | 16.5 VDC | 107.8 A | 122.1 A |
| XP-1100 / 24VDC | 27.6 VDC | 19 / 21 VDC | 33 VDC | 53.9 A | 61.6 A |
| XP-1100 / 48VDC | 55.2 VDC | 41.5 / 42.5 VDC | 62 VDC | 27 A | 30.5 A |
| XP-1100 / 66VDC | 75.9 VDC | 57.5 / 58.5 VDC | 91 VDC | 19.6 A | 22.1 A |
| XP-1100 / 108VDC | 124.0 VDC | 94 / 95 VDC | 149 VDC | 12 A | 13.6 A |

Recommended Input Wire Sizes (For Variable Distances from the Battery):

| MODEL | LESS THAN 5' | LESS THAN 10' | LESS THAN 15' | LESS THAN 20' |
|------------------|--------------|---------------|---------------|---------------|
| XP-600 / 12VDC | 4 AWG | 0 AWG | 0 AWG | 00 AWG |
| XP-600 / 24VDC | 10 AWG | 6 AWG | 4 AWG | 4 AWG |
| XP-600 / 48VDC | 16 AWG | 12 AWG | 10 AWG | 10 AWG |
| XP-600 / 66VDC | 18 AWG | 16 AWG | 14 AWG | 12 AWG |
| XP-600 / 108VDC | 18 AWG | 18 AWG | 18 AWG | 16 AWG |
| XP-1100 / 12VDC | 0 AWG | 00 AWG | 0000 AWG | 0000 AWG |
| XP-1100 / 24VDC | 6 AWG | 4 AWG | 2 AWG | 0 AWG |
| XP-1100 / 48VDC | 12 AWG | 10 AWG | 8 AWG | 6 AWG |
| XP-1100 / 66VDC | 16 AWG | 12 AWG | 10 AWG | 10 AWG |
| XP-1100 / 108VDC | 18 AWG | 16 AWG | 14 AWG | 14 AWG |

Note: The table specifies standard wire sizes (not smaller than 18 AWG) that will provide less than a 2% voltage drop at Low-line Input voltage and Rated Output Power.

See page 13 for Mechanical dimensions and mounting hole locations.

APPENDIX A

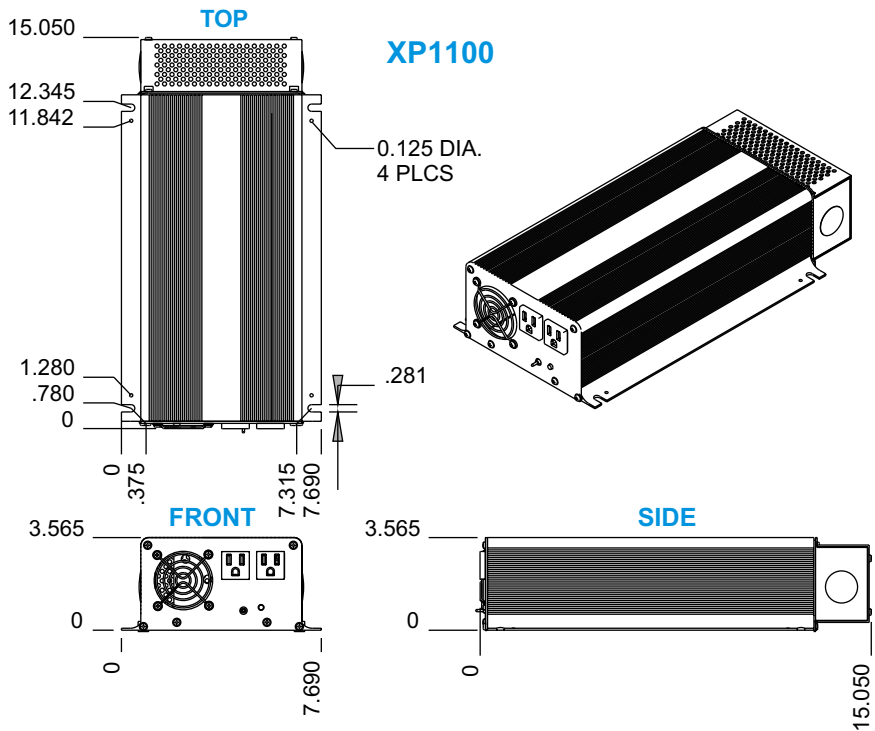
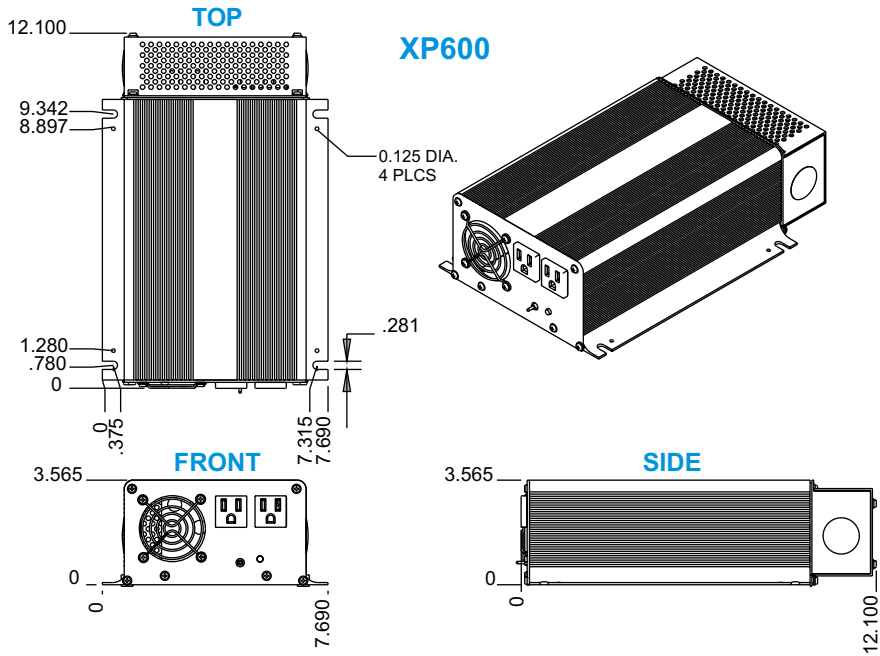

APPENDIX B

Note: Use Rated Current and voltage in Appendix "A" to select an appropriate Toggle Switch or Relay for your specific model inverter.

XP-600 and XP-1100 with DC Toggle Switch:

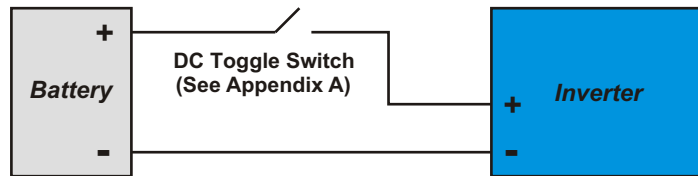

XP-600 and XP-1100 with DC Relay:

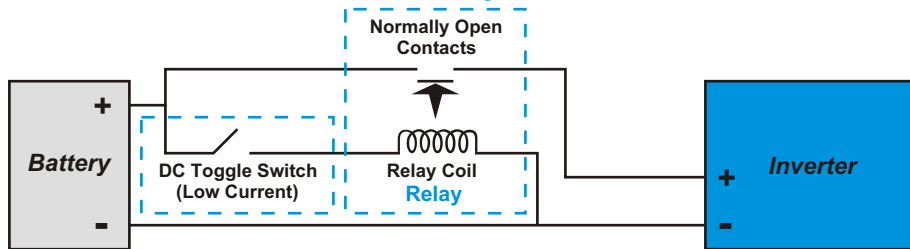

INSTALLATION

CAUTION: Be sure to disconnect all DC power to installation wiring. Be sure to disconnect batteries and chargers. Make all connections to the inverter **BEFORE** connecting DC leads to the battery.

XP-600 and XP-1100 Rear View with access cover removed (AC/DC Connections):

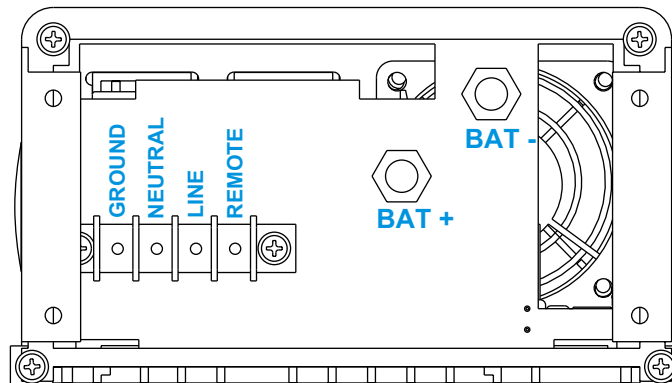

Notes:

Notes:

Made in the USA

EXELTECH

7317 Jack Newell Blvd North
Fort Worth, Texas 76118-7100
817.595.4969 voice, 817.595.1290 fax
800.886.4683 toll free
e-mail address info@exeltech.com
e-mail address sales@exeltech.com
website www.exeltech.com